

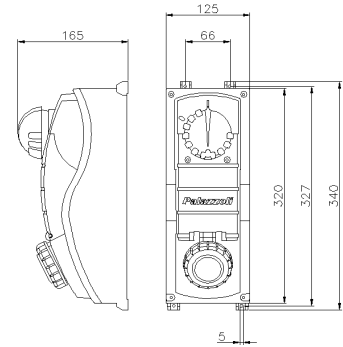

**SERIES ULYSSE
INTERLOCKED SOCKET**
CODE 400139



Datasheet

Electrical characteristics

Rated current	16A
Supply Voltage	230V 50/60Hz ●
Poles	3P+ \perp
Clock Position	9h
Rated insulation voltage	690 V
Insulation Class	II
Type of protection	Fuse 10,3x38 gG max 16A
Signal plug inserted	-

Mechanical characteristics

Manufacturing material	Palazzoli Thermosetting GRP
Treatment type	-
Surface finishing	-
Color	Grey RAL 7035, Blue RAL 5015
Width	125 mm
Execution	Wall mounting
Hole type	Pg29
IP Protection degree	IP66/IP67
Additional IPdegree protection	-
Shock resistance	IK10 according to IEC/EN 62262
Resistance to Glow wire	960°C
Flame rating according UL94	V-0
Corrosivity category	-
Net Weight	2.513 KG
Working Environment Temp.	Min: -50°C ;Max: +60°C
Warehousing Temperature	Min: -50°C ;Max: +80°C

Technical data switch

Thermal current	16 A
Rated short-circuit current	10 kA
Terminals type	Screw - indirect clamping
Conductors section (Cu)	Min: 1 mm ² ;Max: 10 mm ²
Terminal tightening torque	2 Nm
Auxiliary status contacts	Max 2 (optional)
Padlockable handle	2 locks Ø6 mm max

Operating category

Categoria Rating	Tensione Voltage	Corrente / Potenza Current / Power
AC-22A	230 V	16 A
	400 V	16 A
	500 V	16 A
	690 V	16 A
AC-23A	230 V	16 A
	400 V	16 A
	500 V	16 A
	690 V	16 A
AC-23A / AC-3	230 V	5.1 kW
	400 V	8.9 kW
	500 V	11.1 kW
	690 V	15.3 kW

Reference Standards and Directives

Certification and approval marks CE, UKCA

Directives 2011/65/EU (RoHS), 2012/19/EU (WEEE), 2014/35/EU (LVD)

Reference Standards EN 60309-1:1999, EN 60309-1:1999/A1:2007, EN 60309-1:1999/A1AC:2014, EN 60309-1:1999/A2:2012, EN 60309-2:1999, EN 60309-2:1999/A1:2007, EN 60309-2:1999/A2:2012, EN 60309-4:2007, EN 60309-4:2007/A1:2012, EN IEC 63000:2018

The images are purely indicative. Palazzoli reserves the right to make changes without notice.